

Brass Tacks

An in-depth look at a radio-related topic



How spark-gap transmitters worked

In 1887, [Heinrich Hertz discovered that sparks can emit waves](#), which can be received by another, unconnected device, which in turn could reproduce the spark. This ushered in the era of wireless radio communication, and in 1896, Guglielmo Marconi produced the first practical spark-gap transmitters and receivers for radiotelegraphy. One of the first uses of these sparking stations was aboard ships, to communicate with the shore and broadcast a distress call if the ship was in trouble. They played a crucial role in maritime rescues, such as with the 1912 *Titanic* disaster.

From the time of Marconi's first transmitters until 1918, most amateur experimenters and professional operators used spark-gap transmitters in their stations. Soon after World War I, transmitters based on vacuum tubes replaced spark-gap devices, because they a) were less expensive, b) had a greater range, c) produced less interference, d) could carry audio, and e) could be used to produce a continuous wave (CW), which spark-gaps could not. The spark-gap transmitter became obsolete by 1920, and eventually, prohibited by international law in 1934.

Anatomy of the original spark-gap transmitter

So, if spark-gap transmitters are no longer legal to operate, why are we taking about them? Mostly because it's part of our amateur history, and hams like you and I are simply curious. I would hope that nobody reading this article will actually build one of these devices and use it contrary to the rule of law, but I'm going to describe their inner workings to help you understand how they work, and why we no longer use them.

Like most electrical devices, spark-gap stations began primitively from a low-powered bread-board device, and [evolved into a kilovolt engineering marvel](#). I don't intend to describe all their different incarnations, but a few major milestones might help you better envision how and why they worked, and appreciate what went through the designers' heads to get them there.

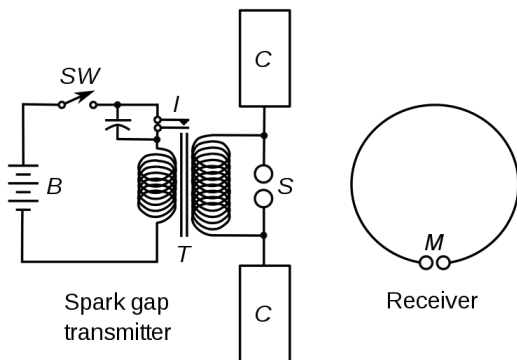

Hertz experimented endlessly making waves from sparks, and eventually developed the *Hertz Spark Oscillator* to the left. Essentially, battery voltage was switched on to charge the capacitor, which in those days was a *Leyden jar* similar to that used by Benjamin Franklin to store charge. Closing the keyer shorted the capacitor, which could not drop to zero volts immediately, resulting in a large rise in voltage across the primary winding. The much greater voltage across the secondary winding produced the spark across the gap. The large, momentary voltage difference between the two metal paddles connected to the spark gap gave rise to electromagnetic radiation, as predicted by James Max-

well years before. The radiation propagated through the air and struck the metal receiver ring, which picked up the radiation, converted it to an electrical signal (which manifested as a spark between two close conductors on a ring, in the demonstration.)

Brass Tacks

continued



The Hertz circuit was a start, but had severe limitations, such as wide-band noise, low emitted energy, and a short transmitting range, a maximum of about 10 miles.

The Marconi spark-gap transmitter

Researchers such as Nikola Tesla eventually improved on the Hertz circuit by moving the large capacitor to [across the secondary winding of the transformer](#). This single modification allowed sufficient charge to build before firing at the gap, thereby making for a significant increase in gap current, which in turn produced a significant radiation emission increase at the antenna. A side benefit, the placement of the large capacitor also narrowed the bandwidth of the emission (which therefore improved efficiency), reducing interference to other receivers significantly.

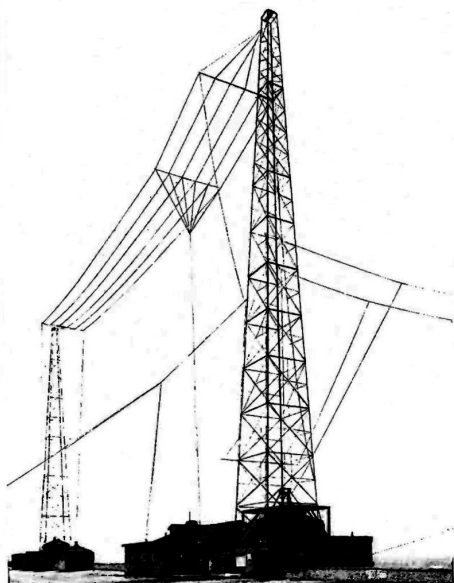
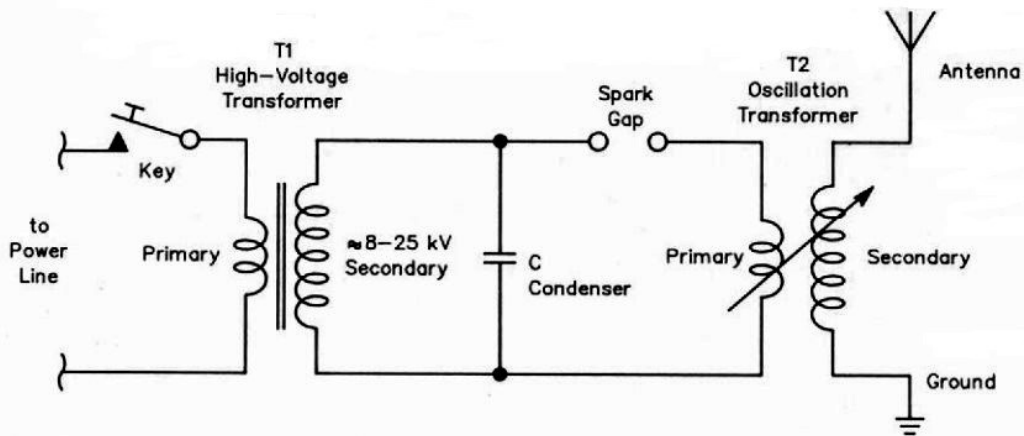

Using this updated design, Marconi was able to extend the range of radio transmissions, due to the extra high voltages now available at the antenna. He also discovered two more effects that helped improve the range of his transmissions: antenna capacitance and antenna height. Using an antenna that had a lot of top-loaded capacitance helped offset (*tune*, if you will) the inductance of the oscillation transformer. One such antenna is the now-obsolete "T" antenna, shown here on the left, and was the type used aboard the *RMS Titanic*. The horizontal wires of the T antenna did not radiate, but provided capacitance, making the antenna power output more efficient.

Through a lot of trial-and-error, Marconi discovered that, the higher he raised his antenna, the farther the transmitted signal could be received. With the combination of both top-loaded capacitance and height, Marconi achieved a maximum transmission distance of over 150 miles.

Brass Tacks

continued



More spark-gap improvements

One of the biggest problems with the Marconi circuit is the production of two separate transmitting frequencies, introduced by the two resonant circuits. Since the circuit output could only be tuned to a single frequency, the energy from the other transmission was essentially wasted. In 1906, German physicist Max Wien devised a [new kind of spark gap](#) that suppressed the signal from the primary transmission, called the *quenched gap*, made from a series of closely separated disks instead of two balls.

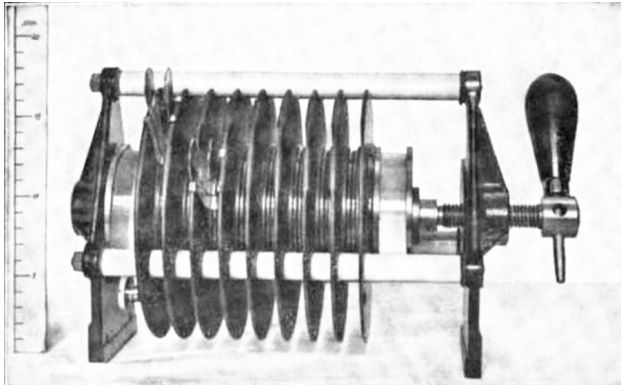

quenched spark gap

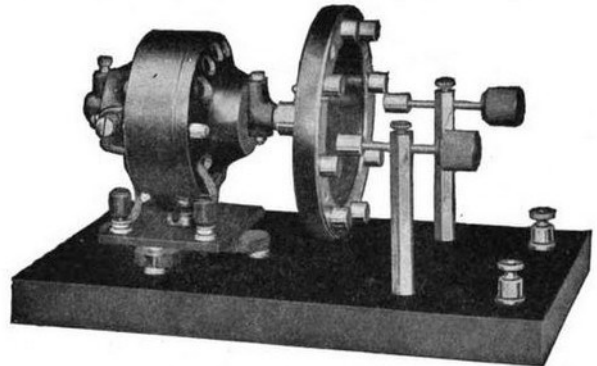

rotary spark gap

Another type of quenched gap, invented by Nikola Tesla in 1896, and later patented by Reginald Fessenden in 1907, consisted of a disk of spark electrodes that spun at high speed by a motor. The idea behind this *rotary spark gap* was to make the spark connection with one of the resonant circuits, then extinguish the spark by rotating the electrode away after the energy had been transferred to the secondary circuit. The result was a higher spark rate, which gave rise to a less noisy signal with a narrower bandwidth, and a cooler-running transmitter.

The elusive search for CW

By the start of World War I, it was long known that a *continuous wave* would provide a better signal solution than spark, because CW occupies a very small bandwidth. The biggest obstacle for CW, however, was that it did not allow for full break-in, like spark did, which was important to professional telegraphers. Spark was always an on-and-off signal, but an operator would have to wait until the end of a CW transmission before the carrier dropped, to break in with a bulletin, for example.

With the 1907 invention of the triode tube by Lee De Forest and the development of the vacuum-tube feedback electronic oscillator by

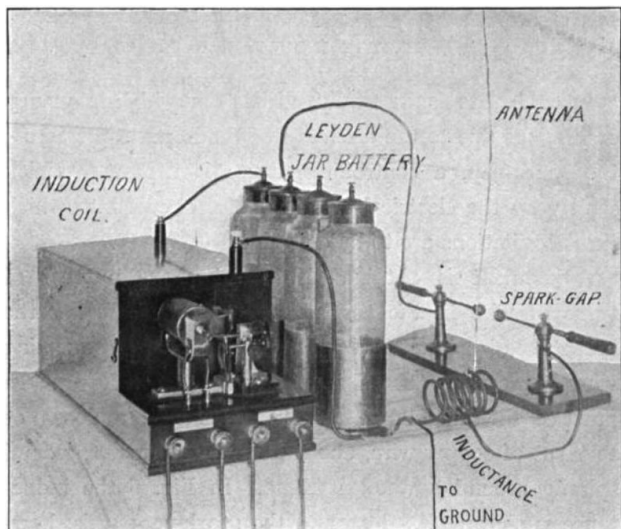

Brass Tacks

continued



Edwin Armstrong in 1912, CW was finally suitable for radio transmission as a practical mode, allowing for full break-in, very low bandwidth, and could easily be modulated to carry audio. It was a safe and inexpensive alternative to spark, and eventually spelled the end of the Spark Era. The 1927 International Radiotelegraph Convention prohibited licensing of new spark transmitters after 1929. Use of all spark transmitters were banned after 1934, except in an emergency. Finally, in 2007 the FCC made it a felony to operate a spark-gap transmitter, due to the likelihood of international interference.

Why all the fuss?

It's very difficult, if not impossible, to confine the emission of a spark-gap signal to a bandwidth that's narrow enough to prevent interfering with adjacent signals. When a spark-gap transmitter is operating, you can receive it for miles around, and across many frequencies. If two spark transmitters are operating simultaneously within a five-mile radius, a receiver is unable to distinguish the two interfering signals from each other and raw static. So, if you're operating a spark transmitter in town, yours is the *only* transmitter in town.



Marconi, 1901, with his early spark transmitter (on his left) and coherer receiver (his right), which recorded the Morse code symbols with an ink line on paper tape

In closing

Do we use spark-gap transmitters today? Nearly [everybody who operates a motor vehicle](#) also runs a spark-gap transmitter, complete with battery, induction coil (ignition coil), capacitor (condenser), antenna (ignition wiring), and spark gap (spark plug). The only thing your vehicle is missing is the keyer. Arc welders do the same, and with similar components. And yes, we're all guilty of emitting the same wide-band noise that outlawed professional and amateur spark-gap transmitters. Today's noise suppression techniques are superior to those of olden days, but they're far from perfect, and still permit some interference.

Noji Ratzlaff, KNØJI (kn0ji@arrl.net)